

## TUBUX M30

Float flowmeter



---

## **LEGAL NOTICE**

All rights reserved Any reproduction of this documentation, even in part and regardless of the method used, is prohibited without the prior written consent of MECON GmbH.

Subject to change without notice.

Copyright 2021 by MECON GmbH - Röntgenstraße 105 - 50169 Kerpen - Germany

---

## Contents

<b>1</b>	<b>SAFETY INFORMATION.....</b>	<b>4</b>
1.1	Intended use.....	4
1.2	Certifications .....	5
1.3	Manufacturer's safety information .....	6
<b>2</b>	<b>SCOPE OF EQUIPMENT.....</b>	<b>7</b>
2.1	Scope of delivery .....	7
2.2	Device versions .....	7
2.3	Nameplate .....	8
<b>3</b>	<b>INSTALLATION AND OPERATION.....</b>	<b>9</b>
3.1	Notes on installation .....	9
3.2	Installation .....	9
3.3	Mode of operation.....	10
<b>4</b>	<b>COMMISSIONING.....</b>	<b>11</b>
4.1	Contacts GSTA, GSTB and GSTW.....	12
<b>5</b>	<b>SERVICE.....</b>	<b>16</b>
5.1	Storage .....	16
5.2	Maintenance .....	16
5.3	Returning the measuring device to the manufacturer .....	16
5.4	Disposal .....	17
<b>6</b>	<b>NOTES .....</b>	<b>18</b>

# 1 SAFETY INFORMATION

## 1.1 Intended use

The TUBUX M30 float flowmeter is used to measure transparent liquid and gas flows in closed pipelines. Optionally, the device can also be used for flow monitoring if it is equipped with one or more contact switches.

The device is particularly suitable for the measurement of water, transparent liquids and gas flows. The main areas of application for the TUBUX M30 are in plant and mechanical engineering, building services engineering, and water and wastewater management.



### ***Warning!***

***Responsibility for the use of the meters with regard to suitability, intended use and, in particular, the corrosion resistance of the materials used with respect to the medium to be measured lies solely with the owner. In particular, it must be ensured that the materials selected for the wetted parts of the meter are suitable for the process media that are used.***

***The manufacturer is not liable for any damage caused by improper use or use not in accordance with the intended purpose of these devices.***

***The device may only be used within the pressure and temperature limits specified in the operating manual.***

***No external loads may act on the meter. The flowmeters are primarily designed for static applications.***



### ***Caution!***

***The use of hot process media may result in hot surfaces! There is a risk of burns at surface temperatures above 70°C. Take suitable protective measures, e.g. contact protection. The contact protection must be designed in such a way that the maximum ambient temperature at the device is not exceeded.***

***Before replacing a meter, it is essential to check that the flow meter is free from dangerous pressures.***

## 1.2 Certifications

### CE labelling:



By affixing the CE label, the manufacturer certifies that the TUBUX M30 complies with the legal requirements of the following EU directive, where applicable:

- » Pressure Equipment Directive 2014/68/EU.

The most dangerous permissible media are gases and liquids in group 1.

### Classification as per Pressure Equipment Directive 2014/68/EU:

Nominal diameter	Permissible media	Category
≤ DN 25 (G ¼ to G 1)	Gases fluid group 1 and liquids fluid group 1	Art. 4.3
> DN 25 (G 1¼ to G2)	Gases fluid group 1 and liquids fluid group 1	I



### **Caution!**

***For the ATEX version, the ATEX supplementary operating instructions must be observed!***

### 1.3 Manufacturer's safety information

The manufacturer is not liable for any damage of any kind arising from the use of the meter, including but not limited to direct, indirect, incidental and consequential damages.

Each product purchased from the manufacturer is covered by the warranty as per the relevant product documentation and the General Terms and Conditions.

The manufacturer reserves the right to revise the contents of the documents, including this disclaimer, without prior notice and is not liable in any way for any consequences of such changes.

Responsibility for determining whether the flowmeters are suitable for the intended use lies solely with the owner. MECON GmbH accepts no liability for the consequences of misuse, modifications or repairs carried out by the customer without prior consultation.

In the event of a complaint, the parts in question must be cleaned of hazardous substances and returned to MECON GmbH, unless otherwise agreed.

To avoid injury to the user or damage to the device, it is necessary that you read the information in this operating manual carefully before operating the device.

This operating manual is intended for the correct installation, operation and maintenance of the devices. Special versions and models adapted to special applications are not the subject of this documentation.

## 2 Scope of equipment

### 2.1 Scope of delivery

- » Flowmeter TUBUX M30
- » Operating manual
- » Calibration certificate

### 2.2 Device versions

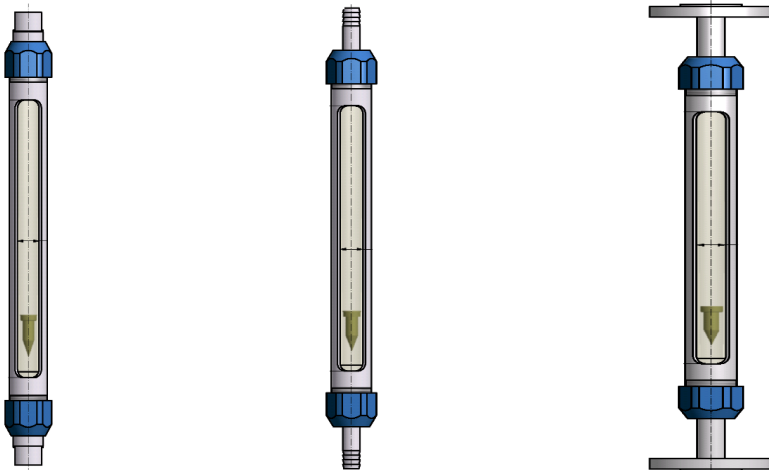

Fig. 1: TUBUX M30 with female thread, hose nozzle and flange connection

The main components of TUBUX M30 flowmeters are the glass measuring cone with float, the fitting and the connecting parts. The display is on the scale on the measuring cone (e.g. in l/h). The reading edge is located at the largest diameter of the float. The device can optionally be equipped with one or more contacts for process monitoring and control.

#### Special features:

- » Product scales for liquids and gases
- » Robust design with a variety of materials
- » Can be used for high pressures and temperatures
- » Short delivery times for standard versions.

## 2.3 Nameplate

 <b>MECON</b> <b>SAFETY CONTROL</b> D-50169 Kerpen www.mecon.de	TYPE: <b>Tubux M30</b> MODEL : <b>7ME5812-4FF14-ODF0/Y01</b>	
	SERIAL NO. : <b>2020-380247/001 001</b>	
	TS: <b>100 °C</b> PS : <b>10 bar</b> Pmax at Tmax: <b>10 bar</b>	
	TEMPERATURE RANGE : <b>0 to 100 °C</b>	
	MANUFACTURING DATE : <b>03.2020</b> PED : <b>SEP</b>	
	TAG-No. : <b>----</b>	

Fig. 2: Nameplate TUBUX M30

- ① Device type
- ② Designation code
- ③ Serial number
- ④ Maximum permissible media temperature
- ⑤ Maximum permissible operating pressure
- ⑥ Maximum permissible operating pressure at TS
- ⑦ Temperature range
- ⑧ Date of manufacture
- ⑨ Classification according to Pressure Equipment Directive (2014/68/EU)
- ⑩ User-defined device identification
- ⑪ CE labelling



## 3 Installation and operation

### 3.1 Notes on installation



#### *Information!*

*All devices have been carefully checked to ensure proper functioning before shipment. Carefully check the outer packaging for damage or signs of improper handling immediately after receipt.*

*Report any damage to the carrier and to your responsible sales representative. In such cases please provide a description of the damage, the type and the serial number of the meter.*

*Unpack the device carefully to avoid damage.*

*Check the completeness of the delivery by referring to the packing list. Check whether the delivered flowmeter corresponds to your order by referring to the nameplate.*

### 3.2 Installation

#### **Installation**

Ensure that the actual operating conditions (pressure and temperature) do not exceed the limits indicated on the nameplate.

For certain device sizes, the float is placed in a plastic net to secure it for transport. This must be pulled upwards out of the meter before installation. The free movement of the float in the measuring cone should then be checked again.

The device must be installed vertically and free of stress. Reductions, extensions and control elements upstream or downstream of the measuring device have no influence on the measuring accuracy for liquids. For gases, however, we recommend installing the meter upstream of valves to avoid compression vibrations. Since variable area flowmeters are very sensitive to changes in flow, the regulating elements should always be adjusted slowly. Calibration is carried out for defined medium conditions. Deviations in density, pressure or temperature in gases, as well as changes in density and viscosity in liquids, cause measurement errors.

It is important to pay attention to compliance with the calibration conditions. Information concerning the medium, the density and the viscosity at operating temperature and pressure is therefore necessary. For gases, the precise reference point of the pressure (gauge or absolute pressure) is also required. Retrofitting of contact switches is only possible if the floats with inserted magnets are used. During commissioning, the float must be guided completely past the contact for polarisation.

### 3.3 Mode of operation

Flowmeters using the float principle operate using a vertical, conical measuring tube made of glass, metal or plastic. In it, a float with a special design can move up and down freely. In this way, the flow values can be read off the scale of the flowmeter at the level of the float measuring edge.

The meter is installed in the piping system in a vertical position so that the medium has to flow from the bottom to the top. Now a float moves on the vertical axis inside the conical body of the measuring device when the medium flows through it. In principle, the float's own weight always causes it to sink to the opening (input side) of the measuring device.

The pressurised medium in the pipe system (buoyancy force  $F_A$ ) causes the float to rise as soon as the dead weight in the measuring cone (weight force  $F_G$ ) is reached, the conical shape widens the meter towards the top. The more the float is pushed upwards, the more of the medium to be measured can flow past the float (flow resistance  $F_R$ ). The float settles at a certain measured value as a result of balanced forces. This measured value represents the flow velocity and is displayed on the scaling based on the float's reading edge (e.g. in l/h) (see figure 3: types of floats). When the volume flow drops, the float also drops again and the measured value changes accordingly.

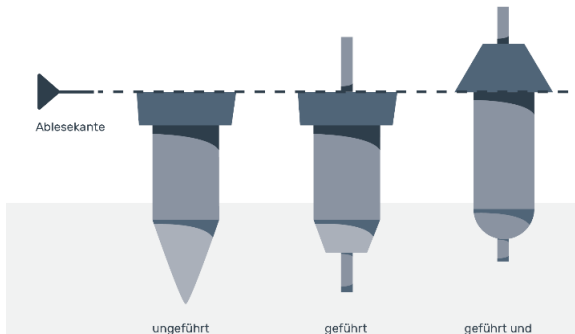

Fig. 3: Types of floats

## 4 Commissioning

Proper installation of the device is a prerequisite for commissioning.

To avoid float bounce, start up against a closed shut-off valve, which is then slowly adjusted to the operating condition. The use of solenoid valves is especially not recommended in this context.

When measuring liquids, make sure that the pipe is carefully vented to prevent pressure surges caused by gas bubbles.

During the commissioning of new plants, residues may increasingly adhere to the float. In such cases, we therefore recommend cleaning the devices after a relatively short period of time.

When using the devices in the lowest measuring range, the device must be operated for a short time at a high flow rate to allow the float to settle.

### **Special aspects of the measurement of gas flows:**

Valves must be fitted downstream of the device if  $p_{abs} > 1.013$  bar and usually upstream of the device if  $p_{abs} = 1.013$  bar (free discharge).

Install a choke directly behind the meter to prevent compression oscillations during measurement.

To avoid erroneous measurements, the arrangement must be selected so that the operating pressure in the meter corresponds to the calibration reference pressure. When measuring gases the operating pressure must be increased slowly to prevent pressure surges.

### **Measured value reading**

The measured value of the float flowmeter TUBUX M30 is read directly from the scale on the measuring cone. The measured value is read at the widest point of the float (see Fig. 4: types of floats).

The measured value that is read off is only correct within the scope of the measuring accuracies if the operating conditions at the measuring point (medium, density, viscosity, operating pressure and operating temperature) correspond to the operating condition data on the scale.

## 4.1 Contacts GSTA, GSTB and GSTW

Limit switches GSTA, GSTB and GSTW are used for the remote monitoring of measured value limits.

The construction consists of an M8x1 threaded sleeve and an angle coupling. A reed switch with a holding magnet is installed in the threaded sleeve. The holding magnet enables bistable switching behaviour. The limit switch is actuated by a permanent magnet built into the float. If it runs past the limit switch, the contact switches.

- » NC contact, NO contact or changeover contact
- » simple to adjust
- » does not require a power supply
- » long service life
- » reliable due to simple mode of operation
- » can be used in explosive areas.

The connection is made to a self-assembly 4-pole M12x1 angled plug made of PA and PBT. Depending on the type of unit it is fixed either to a guide groove or a guide rod. The limit switches can be adjusted over the complete measuring range.

Monitoring of several measuring points is made possible by mounting several limit switches.

Implementation	GSTA	GSTB	GSTW
<b>Switching function</b>	<b>NC contact, bistable</b>	<b>NO contact, bistable</b>	<b>Changeover contact, bistable</b>
Switching voltage	50 V AC / 75 V DC	50 V AC / 75 V DC	50 V AC / 75 V DC
Switching current	max. 0.5 A	max. 0.5 A	max. 0.5 A
Switching capacity	max. 10 W/VA	max. 10 W/VA	max. 5 W/VA
Dielectric strength	230 V AC / 400 V DC	230 V AC / 400 V DC	110 V AC / 200 V DC
Temperatures range *):	-20 ... +90°C	-20 ... +90°C	-20 ... +90°C

\*) Please consider the thermal stability of the flowmeter.

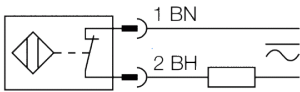

Fig. 4: Connection diagram GSTA

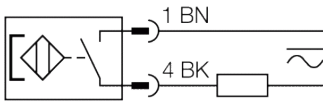

Fig. 5: Connection diagram GSTB

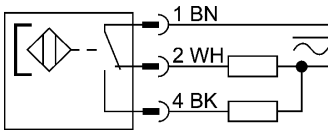

Fig. 6: Connection diagram GSTW

Technical data angle connector M12 x 1	
Plug connector	self-assembly coupling M12 x 1 angled
Number of poles	4-pole, A-coding
Contacts	Metal, CuZn, Optalloy coated
Contact support	Plastic, PA, black
Grip body	Plastic, PBT, black
Seal	Plastic, FKM
Protection Class	IP 67 only when screwed down
Outer diameter of line	4 . 6 mm
Core cross-section	max. 0.75 mm <sup>2</sup>
Screw-in thread	PG 7
Connection type	Screw terminals
Mechanical service life	min. 50 plugging cycles
Cycles degree of contamination	3
Rated voltage	max. 250 V
Insulation resistance	≥ 108 Ω
Current-carrying capacity	4 A
Contact resistance	≤ 8 mΩ
Ambient temperature connector	-25 ... +85°C

**Attention - Low Voltage Directive!**

*Above 50 V AC / 75 V DC, the limit switches are subject to the EU Low Voltage Directive. The user must check their use accordingly.*

**Notes on use**

Uncontrollable current and voltage peaks can occur in the case of inductive or capacitive loads, e.g. from contactors or solenoid valves. Such peaks also occur with cables above a certain length depending on the geometry of the cables. Therefore, the use of an additionally available MSR contact protection relay is recommended. This increases the switching capacity and prevents the occurrence of inductive and capacitive peaks. It thereby ensures that the limit switches have a long service life.

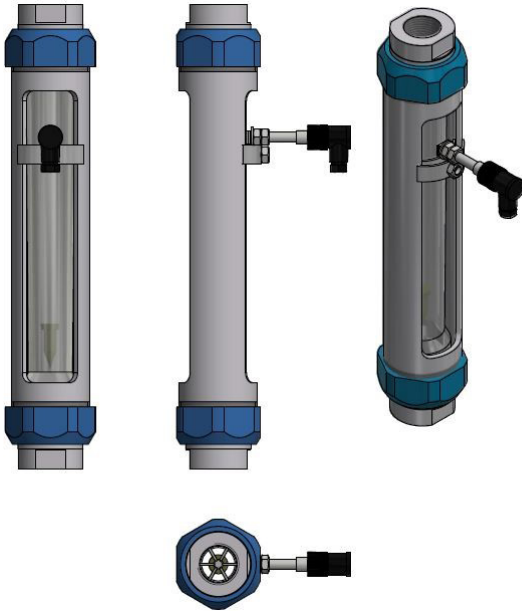
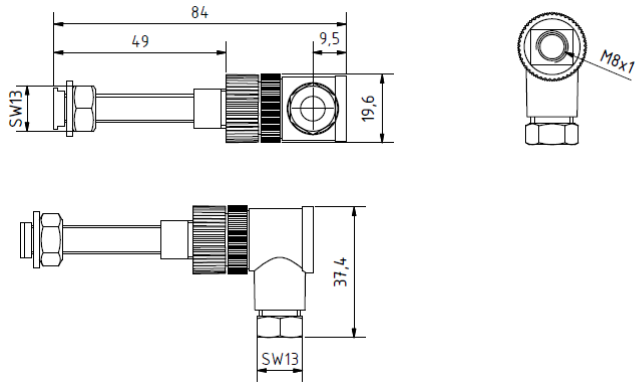

Fig. 7: Contact mounting GSTA, GSTB, GSTW

**Dimensions contacts GSTA, GSTB and GSTW**

*Fig. 8: Contacts GSTA, GSTB and GSTW, dimensions in mm*

## 5 Service

### 5.1 Storage

Store the emptied meter in a dry, dust-free place. Avoid direct sunlight and heat. Avoid external loads on the meter. The permissible storage temperatures are  $-20^{\circ}\text{C}$  to  $+60^{\circ}\text{C}$ .

### 5.2 Maintenance

Although the devices are maintenance-free, we recommend checking the flowmeter at regular intervals for signs of corrosion, mechanical wear as well as damage.

We recommend routine checks at least once a year. The device must be removed from the pipeline for detailed inspection and cleaning. Contamination can lead to measurement errors.



**Caution!**

*Appropriate safety precautions must be taken when removing the device from the pipeline. New seals must be used for new installation in the pipeline.*

### 5.3 Returning the measuring device to the manufacturer

Trouble-free use of the TUBUX M30 can be expected when installed and operated in accordance with this manual thanks to careful manufacturing processes and final inspections of the TUBUX M30.

Should it nevertheless become necessary to return the measuring device to MECON GmbH, please note the following:



**Caution!**

*For reasons of statutory regulations on environmental protection and occupational health and safety, and to preserve the health and safety of our employees, all measuring equipment returned to MECON GmbH for repair must be free of toxic and hazardous substances. This also applies to cavities in the measuring devices. If necessary, the measuring device must be neutralised or rinsed by the customer before its return to MECON GmbH.*



---

*The customer must confirm this by completing a corresponding form, which can be downloaded from the MECON GmbH website, and enclose it with the return shipment:*

»» [www.meccon.de/files/daten/erklaerungen/Dekontaminationserklaerung.pdf](http://www.meccon.de/files/daten/erklaerungen/Dekontaminationserklaerung.pdf)

## 5.4 Disposal



### **Caution!**

*The relevant regulations of your country must be observed when disposing of the measuring instruments.*

---

## 6 Notes





**MECON GmbH**  
Röntgenstr. 105  
50169 Kerpen  
Germany

**Tel.:** +49 (0) 2237 600 06 - 0

**email:** [info@mecon.de](mailto:info@mecon.de)

**website:** [www.mecon.de](http://www.mecon.de)